

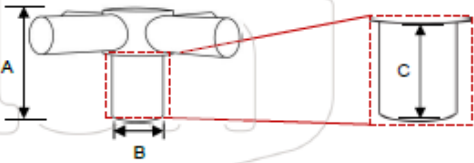

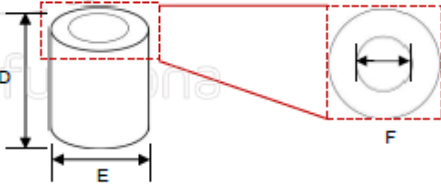
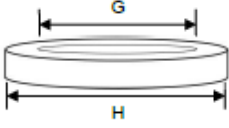

SUPPLIER		ADDRESS		TEL	COUNTRY	REVIEW DATE
EAST PLUMBING (TAIZHOU) MFG. CO., LTD		No.28 HAIFENG ROAD, BINHAI INDUSTRIALZONE, TAIZHOU CITY, ZHEJIANG		+86 (576) 82726333	CHINA	SEPTEMBER 15 <sup>TH</sup> , 2016
ITEMS	DESCRIPTION (FAMILY)					
4070	CROSS HANDLE WITH FLANGE ALL IN BRASS FINISH CROME PLATE					
TESTS	SAMPLING STANDAR	SAMPLING LEVEL		AQL FOR CLASSIFICATION NONCONFORMITIES (TYPE)		
DIMENSIONAL TEST	ISO 2859-1 (MIL STD 105E)	S-2 (SI) LEVEL I	REDUCED INSPECTION	1.-FOR CRITICAL DEFECTIVE	AQL= NOT ALLOWED	
FUNCTIONAL TEST	ISO 2859-1 (MIL STD 105E)	S-4 (SI) LEVEL I	REDUCED INSPECTION	2.-FOR MAYOR DEFECTIVE	AQL= 1.5	
MATERIAL TEST	ISO 2859-1 (MIL STD 105E)	S-2 (SI) LEVEL I	REDUCED INSPECTION	3.-FOR MINOR DEFECTIVE	AQL= 2.5	
APPEARANCE TEST	ISO 2859-1 (MIL STD 105E)	S-2 (SI) LEVEL I	REDUCED INSPECTION			
ARTWORK AND PACKING TEST	ISO 2859-1 (MIL STD 105E)	S-2 (SI) LEVEL I	REDUCED INSPECTION			

TESTS						
DIMENSIONAL						
CONCEPT	SPECIFICATIONS	EQUIPMENT/INSTRUMENT	TEST METHOD		RESULTS	TYPE
ELEMENTARY MEASURES		4070				
A	TOTAL HANDLE HEIGHT	CALIPER			LENGTH, DIAMETERS AND HEIGHT: FLANGES AND HANDLES: TOLERANCE= ± 2mm	1
B	BRASS LEVER WIDTH	PRECISION SCALE			LENGTH, DIAMETERS AND HEIGHT: SCREWS: TOLERANCE= ± 0.2mm  THREADS: WITHOUT BURRS, DIRTY OR ANY OTHER DEFORMATION THAT COULD AFFECT ITS PERFORMANCE.	
C	BRASS LEVER HEIGHT	THREAD PITCH GAUGE			THREADS PER INCH SCREW: 32 THREADS: TOLERANCE= NOT ALLOWED	
D	FLANGE HEIGHT				FLANGE: 18 THREADS TOLERANCE= NOT ALLOWED  WEIGHTS: TOLERANCE= ± 5%	
E	FLANGE WIDTH					
F	FLANGE DIAMETER WIDTH					
G	COMPONENT DIAMETER WIDTH1					
H	COMPONENT DIAMETER WIDTH2					
I	CAP HEIGHT					
J	CAP DIAMETER WIDTH					
K	SCREW HEIGHT					
L	O RING 1 DIAMETER WIDTH					
M	O RING 2 DIAMETER WIDTH					
WEIGHTS (GRAMS)						
	HANDLE					
	FLANGE					
	COMPONENT BRASS					
	CAP					
	SCREW					
	O RING 1					
	O RING 2					
TOTAL WEIGHTS (GRAMS)						

IS PROHIBITED THE TOTAL OR PARTIAL REPRODUCTION OF THIS DOCUMENT WITHOUT PREVIOUS AUTHORIZATION IN WRITING /ROBERTO DE ALAN DE AGUIAR ALMEIDA S.A. DE C.V.

SUPPLIER	ADDRESS	TEL	COUNTRY	REVIEW DATE
EAST PLUMBING (TAIZHOU) MFG. CO., LTD	No.26 HAIFENG ROAD, BINHAI INDUSTRIALZONE, TAIZHOU CITY, ZHEJIANG	+86 (576) 82726333	CHINA	SEPTEMBER 15 <sup>TH</sup> , 2016
ITEMS	DESCRIPTION (FAMILY)			
4070	CROSS HANDLE WITH FLANGE ALL IN BRASS FINISH CROME PLATE			
TESTS	SAMPLING STANDAR	SAMPLING LEVEL	AQL FOR CLASSIFICATION NONCONFORMITIES (TYPE)	
DIMENSIONAL TEST	ISO 2859-1 (MIL STD 105E)	S-2 (SI) LEVEL I	REDUCED INSPECTION	1-FOR CRITICAL DEFECTIVE AQL= NOT ALLOWED
FUNCTIONAL TEST	ISO 2859-1 (MIL STD 105E)	S-4 (SI) LEVEL I	REDUCED INSPECTION	2-FOR MAYOR DEFECTIVE AQL= 1.5
MATERIAL TEST	ISO 2859-1 (MIL STD 105E)	S-2 (SI) LEVEL I	REDUCED INSPECTION	3-FOR MINOR DEFECTIVE AQL= 2.5
APPEARANCE TEST	ISO 2859-1 (MIL STD 105E)	S-2 (SI) LEVEL I	REDUCED INSPECTION	
ARTWORK AND PACKING TEST	ISO 2859-1 (MIL STD 105E)	S-2 (SI) LEVEL I	REDUCED INSPECTION	

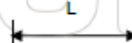
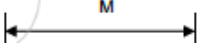
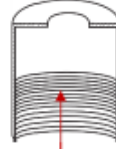
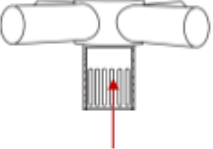
TESTS							
DIMENSIONAL							
CONCEPT	SPECIFICATIONS	EQUIPMENT/INSTRUMENT	TEST METHOD		RESULTS	TYPE	
HANDLE TEETH	12 TEETH	CALIPER				LENGTH, DIAMETERS AND HEIGHT: FLANGES AND HANDLES: TOLERANCE= ± 2mm	1
FLANGE THREADS	18.THREADS	PRECISION SCALE				LENGTH, DIAMETERS AND HEIGHT: SCREWS: TOLERANCE= ± 0.2mm	
SCREW THREADS	32.THREADS	THREAD PITCH GAUGE				THREADS: WITHOUT BURRS, DIRTY OR ANY OTHER DEFORMATION THAT COULD AFFECT ITS PERFORMANCE.	
						THREADS PER INCH	
						SCREW: 32 THREADS: TOLERNACE= NOT ALLOWED	
						FLANGE: 18 THREADS TOLERNACE= NOT ALLOWED	
						TEETH	
						# OF TEETH ON HANDLES: 12 TEETH: TOLERANCE= NOT ALLOWED	
						WEIGHTS: TOLERANCE= ± 5%	

IS PROHIBITED THE TOTAL OR PARTIAL REPRODUCTION OF THIS DOCUMENT WITHOUT PREVIOUS AUTHORIZATION IN WRITING (PROPERTY OF S.I.M. S.p.A. DI ANI/ARCA/INFTRA S.p.A. DI C.V.)