

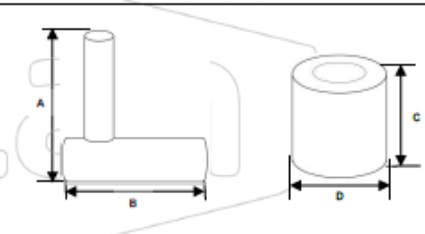



SUPPLIER	ADDRESS	TEL	COUNTRY	REVIEW DATE
EAST PLUMBING (TAIZHOU) MFG. CO., LTD	No. 28 HAIFENG ROAD, BINHAI INDUSTRIAL ZONE, TAIZHOU CITY, ZHEJIANG	+86 (576) 82726333	CHINA	SEPTEMBER, 17 TH , 2016
ITEMS	DESCRIPTION (FAMILY)			
4068	LEVER HANDLE WITH FLANGE ALL IN BRASS FINISH SATIN			
TESTS	SAMPLING STANDAR	SAMPLING LEVEL	AQL FOR CLASSIFICATION NONCONFORMITIES (TYPE)	
DIMENSIONAL TEST	ISO 2859-1 (MIL STD 105E)	S-2 (SI) LEVEL I	REDUCED INSPECTION	1.-FOR CRITICAL DEFECTIVE AQL= NOT ALLOWED
FUNCTIONAL TEST	ISO 2859-1 (MIL STD 105E)	S-4 (SI) LEVEL I	REDUCED INSPECTION	2.-FOR MAYOR DEFECTIVE AQL= 1.5
MATERIAL TEST	ISO 2859-1 (MIL STD 105E)	S-2 (SI) LEVEL I	REDUCED INSPECTION	3.-FOR MINOR DEFECTIVE AQL= 2.5
APPEARENCE TEST	ISO 2859-1 (MIL STD 105E)	S-2 (SI) LEVEL I	REDUCED INSPECTION	
ARTWORK AND PACKING TEST	ISO 2859-1 (MIL STD 105E)	S-2 (SI) LEVEL I	REDUCED INSPECTION	

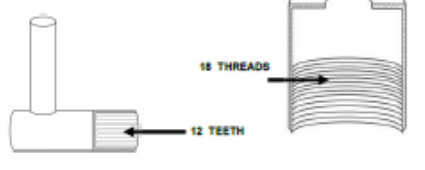

TESTS							
DIMENSIONAL							
CONCEPT	SPECIFICATIONS	EQUIPMENT/INSTRUMENT	TEST METHOD	RESULTS	TYPE		
ELEMENTARY MEASURES	4068	CALIPER	TEST METHOD	LENGTH, DIAMETERS AND HEIGHT: FLANGES AND HANDLES: TOLERANCE= ± 2mm	1		
A	LEVER HEIGHT 57.55 mm (± 2mm)	PRECISION SCALE THREAD PITCH GAUGE		LENGTH, DIAMETERS AND HEIGHT: SCREWS: TOLERANCE= ± 0.2mm			
B	LEVER LENGTH 51.62 mm (± 2mm)						
C	FLANGE HEIGHT 35.14 (± 2mm)						
D	FLANGE DIAMETER 35.10 mm (± 2mm)						
E	INSERT DIAMETER 54.12 mm (± 2mm)						
F	INSERT HEIGHT 5.01 mm (± 2mm)						
G	COVER DIAMETER 10.70mm (± 2mm)	18 THREADS		THREADS: WITHOUT BURRS, DIRTY OR ANY OTHER DEFORMATION THAT COULD AFFECT ITS PERFORMANCE.			
H	O RING DIAMETER (1) 48.67 mm (± 2mm)						
I	O RING DIAMETER (2) 39.61 mm (± 2mm)						
J	SCREW HEIGHT 12.70 (± 2mm)						
							THREADS PER INCH SCREW: 32 THREADS: TOLERANCE= NOT ALLOWED
				TEETH: TEETH ON HANDLES: 12 TEETH TOLERANCE= NOT ALLOWED			
				WEIGHTS: TOLERANCE= ± 5%			
WEIGHTS (GRAMS)	4068						
COVER	1.00 (± 5%)						
SCREW	2.00 (± 5%)						
HANDLE	103.00 (± 5%)						
BODY	65.00 (± 5%)						
FLANGE	40.00 (± 5%)						
O RING 1	2.00 (± 5%)						
O RING 2	1.00 (± 5%)						
TOTAL WEIGHT (GRAMS)	214.00 (± 5%)						

IS PROHIBITED THE TOTAL OR PARTIAL REPRODUCTION OF THIS DOCUMENT WITHOUT PREVIOUS AUTHORIZATION IN WRITING (POPERTY OF ALAN DE AGUASCALIENTES S.A. DE C.V.)

SUPPLIER	ADDRESS	TEL	COUNTRY	REVIEW DATE
EAST PLUMBING (TAIZHOU) MFG. CO., LTD	No. 28 HAIFENG ROAD, BINHAI INDUSTRIAL ZONE, TAIZHOU CITY, ZHEJIANG	+86 (576) 82726333	CHINA	SEPTEMBER, 17 TH , 2016
ITEMS	DESCRIPTION (FAMILY)			
4068	LEVER HANDLE WITH FLANGE ALL IN BRASS FINISH SATIN			
TESTS	SAMPLING STANDAR	SAMPLING LEVEL	AQL FOR CLASSIFICATION NONCONFORMITIES (TYPE)	
DIMENSIONAL TEST	ISO 2859-1 (MIL STD 105E)	S-2 (SI) LEVEL I	REDUCED INSPECTION	1.-FOR CRITICAL DEFECTIVE AQL= NOT ALLOWED
FUNCTIONAL TEST	ISO 2859-1 (MIL STD 105E)	S-4 (SI) LEVEL I	REDUCED INSPECTION	2.-FOR MAYOR DEFECTIVE AQL= 1.5
MATERIAL TEST	ISO 2859-1 (MIL STD 105E)	S-2 (SI) LEVEL I	REDUCED INSPECTION	3.-FOR MINOR DEFECTIVE AQL= 2.5
APPEARENCE TEST	ISO 2859-1 (MIL STD 105E)	S-2 (SI) LEVEL I	REDUCED INSPECTION	
ARTWORK AND PACKING TEST	ISO 2859-1 (MIL STD 105E)	S-2 (SI) LEVEL I	REDUCED INSPECTION	

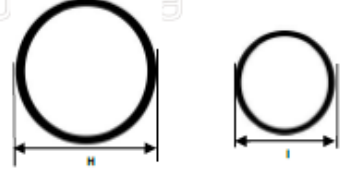

TESTS					
DIMENSIONAL					
CONCEPT	SPECIFICATIONS	EQUIPMENT/INSTRUMENT	TEST METHOD	RESULTS	TYPE
HANDLE TEETH	12 TEETH	CALIPER	TEST METHOD	LENGTH, DIAMETERS AND HEIGHT: FLANGES AND HANDLES: TOLERANCE= ± 2mm	1
FLANGE THREADS	18 THREADS	PRECISION SCALE THREAD PITCH GAUGE		LENGTH, DIAMETERS AND HEIGHT: SCREWS: TOLERANCE= ± 0.2mm	
SCREW THREADS	32 THREADS				
			THREADS: WITHOUT BURRS, DIRTY OR ANY OTHER DEFORMATION THAT COULD AFFECT ITS PERFORMANCE.		
				THREADS PER INCH SCREW: 32 THREADS: TOLERANCE= NOT ALLOWED	
			FLANGE: 18 THREADS TOLERANCE= NOT ALLOWED		
			TEETH: TEETH ON HANDLES: 12 TEETH TOLERANCE= NOT ALLOWED		
			WEIGHTS: TOLERANCE= ± 5%		

IS PROHIBITED THE TOTAL OR PARTIAL REPRODUCTION OF THIS DOCUMENT WITHOUT PREVIOUS AUTHORIZATION IN WRITING (POPERTY OF ALAN DE AGUASCALIENTES S.A. DE C.V.)